

SuperStack® 3 Baseline Hub 12-Port TP (3C16440A) and 24-Port TP (3C16441A) User Guide

DUA1644-0AAA03

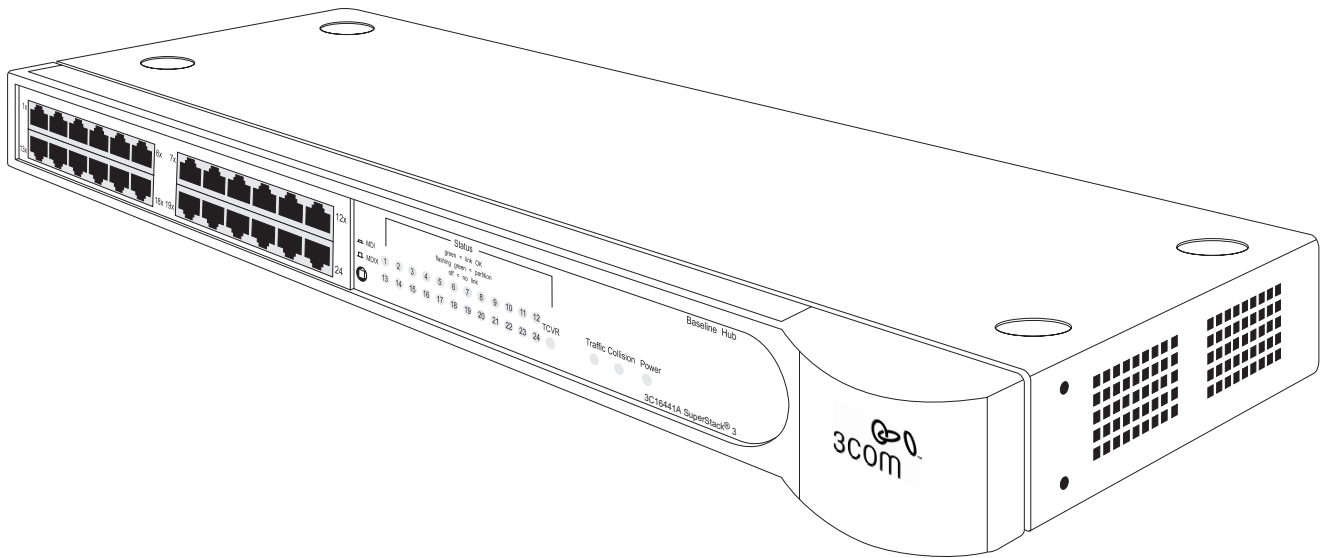

INTRODUCTION

The SuperStack® 3 Baseline Hub is a flexible unmanaged Ethernet repeater which is very easy to use. It can be used in a variety of ways, from building a small network to expanding a larger, more established network.

The SuperStack 3 Baseline Hub 12-port TP (3C16440A) has 12 dedicated shielded twisted pair (TP) ports on the front panel. The SuperStack 3 Baseline Hub 24-port TP (3C16441A) has 24 dedicated shielded twisted pair (TP) ports on the front panel. The rear panel also has a slot for a 3Com Transceiver Module; if fitted, the Module will operate in addition to the TP ports. A range of different media Transceiver Modules is available from 3Com. Contact your supplier for details.

The Baseline Hub comes with:

- One power cord for use with the Baseline Hub
- Four standard height and two reduced height self-adhesive rubber pads
- One rack mounting kit
- A card with details of online registration

The Baseline Hub is suitable for office use where it can be free standing or rack-mounted (in a wiring closet or equipment room). The hub can be powered either from the AC mains supply, or through an optional 3Com® SuperStack Advanced Redundant Power System (3C16071/A/B). Contact your supplier for details.

Network Connections

The Baseline Hub can be used stand-alone or linked with other hubs. Because each Baseline Hub is a single IEEE 802.3 Ethernet repeater hub, there can be a maximum of four Baseline Hubs between any two pieces of Data Terminal Equipment (DTE) (workstations or other equipment) on the same network.

The Baseline Hub is ready to use. You can connect the Hub to any DTE fitted with a 10BASE-T network adapter or a 10BASE-T transceiver. Connect one end of the twisted pair cable to the RJ45 port on the unit and the other end to the RJ45 port on your network adapter or transceiver. You can attach up to 12 or 24 twisted pair segments to the front of the unit.

The Baseline Hub can use both shielded 150 Ohm, and unshielded or shielded 100 Ohm twisted pair cables. To remain within 802.3 10BASE-T rules, the maximum length of cable between the unit and any DTE should not be greater than 100m (328ft). Consult your supplier's technical support department if you need to use twisted pair cables over greater distances.

You can fit one of the 3Com Transceiver Modules into the slot on the rear panel to provide an additional, 13th or 25th port.

You can connect the Baseline Hub to any other 10BASE-T hub or unit using port 12 or 24, to form an inter-repeater link. You must switch port 12 or 24 to MDI to bypass the internal cross-over normally implemented by 10BASE-T unit ports. Refer to "MDI Switch" for information on connecting hubs and switching port 12 or 24 between MDI and MDIX.

HOW TO USE THE BASELINE HUB

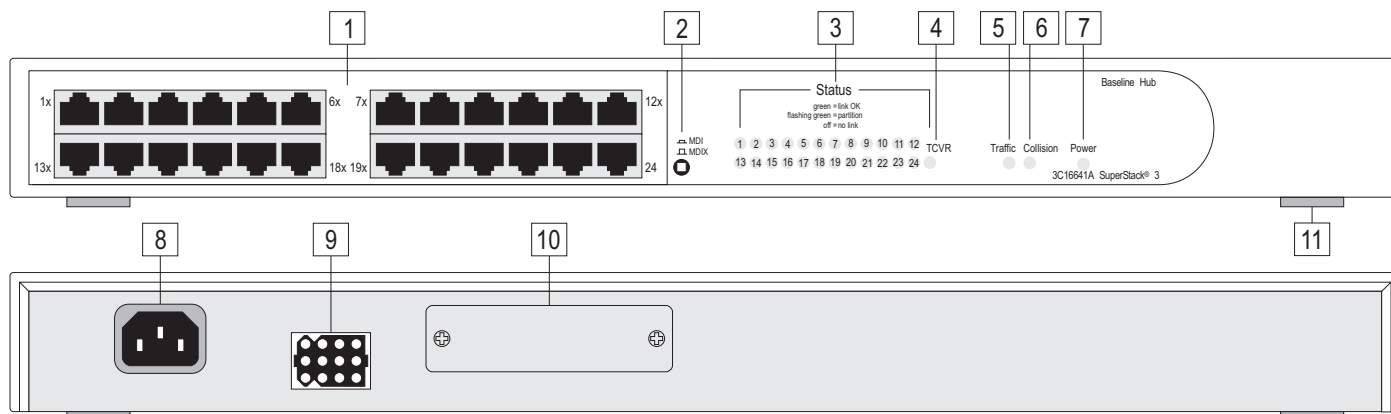

Numbered elements in this diagram refer to numbered sections in the text. These numbers, in bold, are used as references.

Front Panel

1 12 or 24 RJ45 10Base-T Ports



WARNING: RJ-45 Ports. These are shielded RJ-45 data sockets. They cannot be used as standard traditional telephone sockets, or to connect the unit to a traditional PBX or public telephone network. Only connect RJ-45 data connectors, network telephony systems, or network telephones to these sockets. Either shielded or unshielded data cables with shielded or unshielded jacks can be connected to these data sockets.



AVERTISSEMENT: Points d'accès RJ-45. Ceux-ci sont protégés par des prises de données. Ils ne peuvent pas être utilisés comme prises de téléphone conventionnelles standard, ni pour la connexion de l'unité à un réseau téléphonique central privé ou public. Raccorder seulement connecteurs de données RJ-45, systèmes de réseaux de téléphonie ou téléphones de réseaux à ces prises. Il est possible de raccorder des câbles protégés ou non protégés avec des jacks protégés ou non protégés à ces prises de données.



WARNHINWEIS: RJ-45-Porte. Diese Porte sind geschützte Datensteckdosen. Sie dürfen weder wie normale traditionelle Telefonsteckdosen noch für die Verbindung der Einheit mit einem traditionellem privatem oder öffentlichem Telefonnetzwerk gebraucht werden. Nur RJ-45-Datenanschlüsse, Telefonnetzsysteme oder Netztelefone an diese Steckdosen anschließen. Entweder geschützte oder ungeschützte Buchsen dürfen an diese Datensteckdosen angeschlossen werden.

Either shielded or unshielded data cables with shielded or unshielded jacks can be connected to these data sockets.

2 MDI Switch

Ports 1 to 11 (12-port hub) and 1 to 23 (24-port hub) are fixed as MDIX ports so that they can be connected directly to DTE (workstations or other equipment) which have MDI ports using normal 'straight through' TP cables.

Port 12 (12-port hub) and 24 (24-port hub) are switch selectable using the MDI Switch. The ports can be MDIX ports (to connect directly to DTE like the other ports), or MDI ports (to connect to other repeaters using a normal 'straight through' TP cable).



Out In this position you can connect port 12 or 24 to a workstation or any other DTE using a normal 'straight through' TP cable.



In In this position you can connect port 12 or 24 to any MDIX port on another 10BASE-T repeater using a normal 'straight through' TP cable.

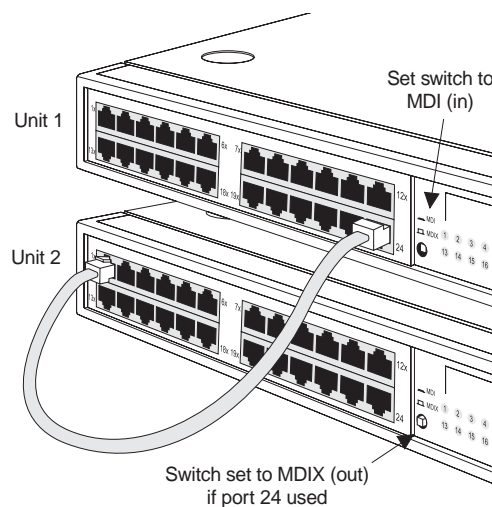

To connect two Baseline Hubs, connect port 12 or 24 on unit 1 to any port on unit 2. Ensure that the MDI switch on unit 1 is IN (MDI) and that if port 12 or 24 is used on unit 2, the MDI switch is OUT (MDIX).

3 TP Status LEDs

The TP Status LEDs show the partition state of a port and whether or not the Link Pulse signal is present on the segment connected to a port:

Green	The Link Pulse signal is being received and the segment attached to the port is functional.
Flashing green	The port is partitioned from the network. <ul style="list-style-type: none"> Check the connections and the cable for any breaks in the segment. Make sure the transceiver attached to the DTE is correctly connected and powered up. Check for illegal 802.3 configurations, in particular, loops. <p>If the cause of the partition is found and corrected, the segment is reconnected automatically, after the first valid packet is transmitted to, or received from the segment.</p>
Off	The Link Pulse signal is not being received. <ul style="list-style-type: none"> Check that the attached DTE is switched on. Check that the attached transceiver is not faulty. If it is port 12 or 24 or an inter-repeater link, check the setting of the MDI switch. Carry out the checks recommended for when a Status LED is flashing green. Check for no more than 4 repeater stacks in series, and that cable lengths do not exceed the maximum specified in the standard for that medium.

If these checks do not identify the cause of a problem, it may be that the Baseline Hub or the device connected to the port is faulty. Contact your supplier for further advice.

4 Transceiver Module Status LED

If a Twisted Pair or Fiber Transceiver Module has been fitted, the LED behaves the same as the TP Status LEDs, refer to 3.

For other Transceiver Modules, the LED shows these states:

Green	Transceiver Module fitted correctly and not partitioned.
Flashing green	Transceiver Module partitioned.
Off	Transceiver Module is faulty or fitted incorrectly.



A Transceiver Module port connected to a coaxial cable segment may partition if the segment is incorrectly terminated.

The Transceiver Module port may partition if the SQE test pulse is enabled on its transceiver. SQE test should be disabled on transceivers used to connect 802.3 repeaters to the network.

5 Traffic LED

The Traffic LED flashes green whenever data is received on one of the twisted pair ports or the Transceiver Module port.

If this LED does not flash, there is no data being received by the unit. If the unit is receiving data but the LED does not flash, the LED has failed. Contact your supplier.

6 Collision LED

The Collision LED flashes yellow when a packet collision has been detected on a segment connected to one of the twisted pair ports or the Transceiver Module port.

Under normal 802.3 Ethernet operation, collisions occur and cause the Collision LED to flash. The probability of collisions increases during heavy activity on the network. The Auto Partition/Reconnection function partitions a segment from the rest of the network if more than 32 consecutive collisions are detected on that segment.

If the Collision LED lights for long periods of time, it indicates a high amount of collisions which can slow your network down. If this happens, you may need to separate parts of your network with a switch. Contact your supplier.

7 Power LED

The Power LED indicates a number of conditions:

Green	The unit is powered on and ready for use.
Off	The unit is powered off. The power cable may be connected incorrectly or the fuse within the power cord's plug may be faulty (UK models only). If the unit appears to be operating and the LED is off, contact your supplier.

Rear Panel Connections

8 Power Supply

The Baseline Hub automatically adjusts to the supply voltage. Only use the power cord that is supplied with the Baseline Hub, or a power cord of the same type and rating.

9 Socket for Redundant Power System

Only connect a 3Com SuperStack 3 Advanced RPS (Redundant Power System) to this socket. For details, follow the installation instructions in the guide accompanying the Redundant Power System.

10 Transceiver Module Slot

A variety of 3Com plug-in Transceiver Modules can be installed in the Baseline Hub. Transceiver Modules provide direct network connections to different media. Contact your supplier for information on the latest Modules.



CAUTION: Do not remove the Transceiver Module blanking plate while the hub is connected to a power source.

Ensure that SQE test is disabled on the Transceiver Module that you are using.

To install a Transceiver Module, refer to the guide that accompanies it. If you subsequently remove the Transceiver Module, you must replace the blanking plate to aid the circulation of cooling air and prevent the entry of dust and debris.

11 Self-adhesive Pads

The Baseline Hub is supplied with four standard height and two reduced height self-adhesive rubber pads. Usage of the feet depends on where the Baseline Hub is placed:

- Use the four standard height pads if the unit is to be placed on a flat surface or stacked with another SuperStack 3 product of the same dimensions.
- Use the two reduced height pads and two of the standard height pads if the unit is to be stacked on a SuperStack 3 unit of different dimensions — Line up the front of the units, and use the two standard height pads at the front (to fit the recess of the unit beneath) and use the two reduced height pads at the back.



Do not apply the pads if you intend to rack mount the hub.

If the hub is to be part of a free standing stack, apply the pads to each marked corner area on the underside of the hub. Place the hub on top of the lower unit, ensuring that the pads of the upper unit locate with the recesses of the lower unit.

Positioning the Baseline Hub



CAUTION: When installing the Baseline Hub in a stack of different size units, the Baseline Hub must be installed above any larger units. Do not have a free standing stack of more than six units.

When deciding where to position the Baseline Hub ensure:

- It is accessible and cables can be connected easily.
- Cabling is away from:
 - sources of electrical noise such as radios, transmitters and broadband amplifiers.
 - power lines and fluorescent lighting fixtures.
- Water or moisture cannot enter the case of the unit.
- Air flow around the unit and through the vents in the side of the case is not restricted (3Com recommends that you provide a minimum of 25mm (1in.) clearance).

To prolong the operational life of your units:

- Never stack units more than six high if free standing, and ensure that cables are supported so that they do not cause the stack to fall over.
- Do not place objects on top of any unit or stack.
- Do not obstruct any vents at the sides of the case.

Power Supply

Power problems can be the cause of serious failures and downtime in your network. Ensure that the power input to your system is clean and free from sags and surges to avoid unforeseen network outages. 3Com recommends that you install power conditioning, especially in areas prone to black outs, power dips and electrical storms.

The unit is intended to be grounded. Ensure it is connected to earth ground during normal use. Installing proper grounding helps to avoid damage from lightning and power surges.

Rack Mounting

The Baseline Hub can be mounted in a 19-inch equipment rack. Refer to "Mounting Kit Instructions".

Power Up

Use the following sequence to power up the Baseline Hub:

- Check the network connections and cables.
- Connect the power supply cable to the appropriate power socket on the rear panel of the unit. Refer to 8 or 9.
- Connect the plug to the power supply outlet socket. If you are using a 3Com Redundant Power System, ensure that it is switched on.

When the Baseline Hub is powered on, the Power LED should be lit. If it is not, refer to 7, "Power LED".

SAFETY INFORMATION

Please read the following safety information carefully before installing the Baseline Hub.



WARNING: Installation and removal of the unit must be carried out by qualified personnel only.

- The unit must be connected to an earthed (grounded) outlet to comply with international safety standards.
- Do not connect the unit to an A.C. outlet (power supply) without an earth (ground) connection.
- The appliance coupler (the connector to the unit and not the wall plug) must have a configuration for mating with an EN60320/IEC320 appliance inlet.
- The socket outlet must be near to the unit and easily accessible. You can only remove power from the unit by disconnecting the power cord from the outlet.
- This unit operates under SELV (Safety Extra Low Voltage) conditions according to IEC 60. The conditions are only maintained if the equipment to which it is connected also operates under SELV conditions.
- Only connect an *Advanced Redundant Power System* (3C16070, 3C16071, 3C16071A or 3C16071B) or *Redundant Power System* (3C565047) to the *Redundant Power System* socket.

France and Peru only

This unit cannot be powered from IT[†] supplies. If your supplies are of IT type, this unit must be powered by 230V (2P+T) via an isolation transformer ratio 1:1, with the secondary connection point labelled Neutral, connected directly to earth (ground).

[†] Impédance à la terre

Power Cord Set

This must be approved for the country where it will be used. e.g.

- | | |
|--------------------------|--|
| U.S.A. and Canada | <ul style="list-style-type: none">■ The cord set must be UL-approved and CSA certified.■ The minimum specifications for the flexible cord are:
No. 18 AWG
Type SV or SJ
3-conductor■ The cord set must have a rated current capacity of at least 10A.■ The attachment plug must be an earth-grounding type with a NEMA 5-15P (15A, 125V) or NEMA 6-15P (15A, 250V) configuration. |
| Denmark | <ul style="list-style-type: none">■ The supply plug must comply with Section 107-2-D1, Standard DK2-1a or DK2-5a. |
| Switzerland | <ul style="list-style-type: none">■ The supply plug must comply with SEV/ASE 1011. |
| UK | <ul style="list-style-type: none">■ The supply plug must comply with BS1363 (3-pin 13-amp) and be fitted with a 5A fuse which complies with BS1362.■ The mains cord must be <HAR> or <BASEC> marked and be of type HO3VVF3GO.75 (minimum). |
| Europe | <ul style="list-style-type: none">■ The supply plug must comply with CEE7/7 ("SCHUKO")■ The mains cord must be <HAR> or <BASEC> marked and be of type HO3VVF3GO.75 (minimum). |

L'INFORMATION DE SÉCURITÉ IMPORTANTE

Veillez lire à fond l'information de la sécurité suivante avant d'installer le Baseline Hub.



AVERTISSEMENT: L'installation et la dépose de ce groupe doivent être confiés à un personnel qualifié.

- Ne branchez pas votre appareil sur une prise secteur (alimentation électrique) lorsqu'il n'y a pas de connexion de mise à la terre (mise à la masse).
- Vous devez raccorder ce groupe à une sortie mise à la terre (mise à la masse) afin de respecter les normes internationales de sécurité.
- Le coupleur d'appareil (le connecteur du groupe et non pas la prise murale) doit respecter une configuration qui permet un branchement sur une entrée d'appareil EN60320/IEC 320.
- La prise secteur doit se trouver à proximité de l'appareil et son accès doit être facile. Vous ne pouvez mettre l'appareil hors circuit qu'en débranchant son cordon électrique au niveau de cette prise.
- L'appareil fonctionne à une tension extrêmement basse de sécurité qui est conforme à la norme IEC60950. Ces conditions ne sont maintenues que si l'équipement auquel il est raccordé fonctionne dans les mêmes conditions.
- Branchez uniquement un *Advanced Redundant Power System* (3C16070, 3C16071, 3C16071A ou 3C16071B) ou un *Redundant Power System* (3C565047) sur la prise femelle du *Redundant Power System*.

France et Pérou uniquement:

Ce groupe ne peut pas être alimenté par un dispositif à impédance à la terre. Si vos alimentations sont du type impédance à la terre, ce groupe doit être alimenté par une tension de 230 V (2 P+T) par le biais d'un transformateur d'isolement à rapport 1:1, avec un point secondaire de connexion portant l'appellation Neutre et avec raccordement direct à la terre (masse).

Cordon électrique

Il doit être agréé dans le pays d'utilisation.

- | | |
|-----------------------------|--|
| Etats-Unis et Canada | <ul style="list-style-type: none">■ Le cordon doit avoir reçu l'homologation des UL et un certificat de la CSA.■ Le cordon souple doit respecter, à titre minimum, les spécifications suivantes:
calibre 18 AWG
type SV ou SJ
à 3 conducteurs■ Le cordon doit être en mesure d'acheminer un courant nominal d'au moins 10 A.■ La prise femelle de branchement doit être du type à mise à la terre (mise à la masse) et respecter la configuration NEMA 5-15P (15 A, 125 V) ou NEMA 6-15P (15 A, 250 V). |
| Danemark | <ul style="list-style-type: none">■ La prise mâle d'alimentation doit respecter la section 107-2 D1 de la norme DK2 1a ou DK2 5a. |
| Suisse | <ul style="list-style-type: none">■ La prise mâle d'alimentation doit respecter la norme SEV/ASE 1011. |
| Europe | <ul style="list-style-type: none">■ La prise secteur doit être conforme aux normes CEE 7/7 ("SCHUKO")■ LE cordon secteur doit porter la mention <HAR> ou <BASEC> et doit être de type HO3VVF3GO.75 (minimum). |

WICHTIGE SICHERHEITSINFORMATIONEN

Bitte unbedingt vor dem Einbauen des Baseline Hub Einheit die folgenden Sicherheitsanweisungen durchlesen.



WARNUNG: Die Installation und der Ausbau des Geräts darf nur durch Fachpersonal erfolgen.

- Das Gerät nicht an eine Wechselstromsteckdose anschließen, die nicht geerdet ist.
- Das Gerät muß an eine geerdete Steckdose angeschlossen werden, die die internationalen Sicherheitsnormen erfüllt.
- Der Gerätestecker (der Anschluß an das Gerät, nicht der Wandsteckdosenstecker) muß eine passende Konfiguration für einen Geräteeingang gemäß EN60320/IEC320 haben.
- Die Netzsteckdose muß in der Nähe des Geräts und leicht zugänglich sein. Die Stromversorgung des Geräts kann nur durch Herausziehen des GeräteNetzkaabels aus der Netzsteckdose unterbrochen werden.
- Der Betrieb dieses Geräts erfolgt unter den SELV-Bedingungen (Sicherheitskleinstspannung) gemäß IEC 60. Diese Bedingungen sind nur gegeben, wenn auch die an das Gerät angeschlossenen Geräte unter SELV-Bedingungen betrieben werden.
- Nur ein *Advanced Redundant Power System* (3C16070, 3C16071, 3C16071A oder 3C16071B) oder *Redundant Power System* (3C565047) an den *Redundant Power System* Anschluß anschließen.

Stromkabel

Dies muss von dem Land, in dem es benutzt wird geprüft werden:

- | | |
|----------------|--|
| Schweiz | <ul style="list-style-type: none">■ Dieser Stromstecker muß die SEV/ASE 1011 Bestimmungen einhalten. |
| Europe | <ul style="list-style-type: none">■ Das Netzkabel muß vom Typ HO3VVF3GO.75 (Mindestanforderung) sein und die Aufschrift <HAR> oder <BASEC> tragen.■ Der Netzstecker muß die Norm CEE 7/7 erfüllen ("SCHUKO"). |

MOUNTING KIT INSTRUCTIONS

The Baseline Dual Speed Hub is supplied with two mounting brackets and four screws. These are used for rack mounting the unit. When mounting the unit, you should take note of the guidelines given in "Positioning the Baseline Hub" on page 3.

The Baseline Dual Speed Hub is 1U high and will fit a standard 19-inch rack.

CAUTION: Disconnect all cables from the unit before continuing. Remove the self-adhesive pads from the underside of unit, if already fitted.

To rack mount the unit:

- 1 Place the unit the right way up on a hard, flat surface with the front facing towards you.
- 2 Locate a mounting bracket over the mounting holes on one side of the unit, as shown in the diagram.
- 3 Insert the two screws supplied in the mounting kit and fully tighten with a suitable screwdriver.
- 4 Repeat the two previous steps for the other side of the unit.
- 5 Insert the unit into the 19-in. rack and secure with suitable screws (not provided).
- 6 Reconnect all cables.

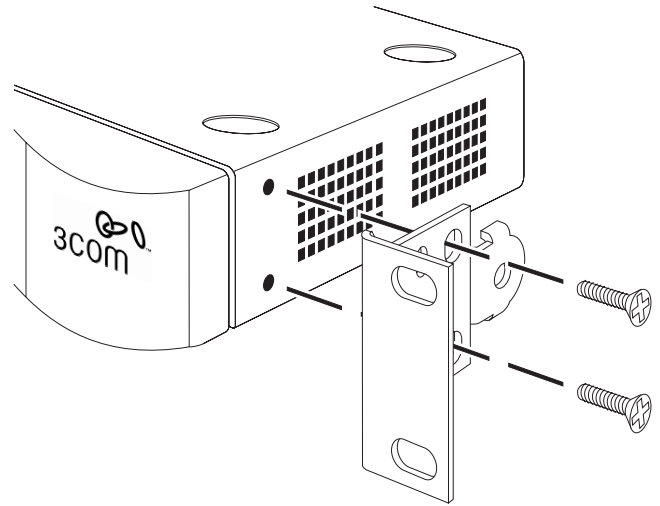

PROBLEM SOLVING

If the Baseline Hub fails to operate successfully, contact your supplier with the following information before returning the unit:

- product number and serial number (printed on a label on the back of the unit)

- a brief description of the fault

When returning any equipment to your supplier ensure that the equipment is packed suitably for transit.

TECHNICAL INFORMATION

Related Standards

The SuperStack 3 Baseline Hub has been designed to the following standards:

Functional	ISO 8802-3, IEEE 802.3 (Ethernet), IEEE 802.3u (Fast Ethernet), IEEE 802.3x (Flow Control)
Safety	UL 1950, EN 60950, CSA 22.2 #950, IEC 60950
EMC Emissions	EN 55022 Class A, FCC Part 15 Subpart B Class A, ICES-003 Class A, VCCI Class A, AS/NZS 3548 Class A, CNS 13438 Class A, EN61000-3-3, EN61000-3-2
Immunity	EN 55024
Physical	
Width	440 mm (17.3 in.)
Depth	173 mm (6.8 in.)
Height	44 mm (1.7 in.) or 1 U
Weight	2.6 kg (5.8 lb)
Mounting	Free standing, or 19 in. rack mounted using the mounting kit supplied

Electrical

Power Inlet	IEC 320
AC Line Frequency	50/60 Hz
Input Voltage	90–240 VAC
Current Rating	1 Amps (maximum)
Maximum Power Consumption	3C16464B: 49 VA 3C16465B: 88 VA
Maximum Power Dissipation	3C16464B: 165 BTU/hr 3C16465B: 300 BTU/hr

Environmental

Operating Temperature	0–50°C (32–122°F)
Humidity	10–95% (non-condensing)
Standard	EN 60068 (IEC 68)—various parts

LIMITED WARRANTY

This warranty applies to customers located in the United States, Australia, Canada (except Quebec), Ireland, New Zealand, U.K., and other English language countries, and countries for which a translation into the local language is not provided.

SuperStack 3 Baseline Hub 12-Port TP (3C16440A) and 24-Port TP (3C16441A)

HARDWARE: 3Com warrants to the end user ("Customer") that this hardware product will be free from defects in workmanship and materials, under normal use and service, for the following length of time from the date of purchase from 3Com or its authorized reseller:

Lifetime, for as long as the original Customer owns the product (not transferable to a subsequent end user)

3Com's sole obligation under this express warranty shall be, at 3Com's option and expense, to repair the defective product or part, deliver to Customer an equivalent product or part to replace the defective item, or if neither of the two foregoing options is reasonably available, 3Com may, in its sole discretion, refund to Customer the purchase price paid for the defective product. All products that are replaced will become the property of 3Com. Replacement products or parts may be new or reconditioned. 3Com warrants any replaced or repaired product or part for ninety (90) days from shipment, or the remainder of the initial warranty period, whichever is longer.

SOFTWARE: 3Com warrants to Customer that each software program licensed from it, except as noted below, will perform in substantial conformance to its program specifications, for a period of ninety (90) days from the date of purchase from 3Com or its authorized reseller. 3Com warrants the media containing software against failure during the warranty period. No updates are provided, unless specifically included in the Included Services section. 3Com's sole obligation under this express warranty shall be, at 3Com's option and expense, to refund the purchase price paid by Customer for any defective software product, or to replace any defective media with software which substantially conforms to applicable 3Com published specifications. Customer assumes responsibility for the selection of the appropriate applications program and associated reference materials. 3Com makes no warranty or representation that its software products will meet Customer's requirements or work in combination with any hardware or applications software products provided by third parties, that the operation of the software products will be uninterrupted or error free, or that all defects in the software products will be corrected. For any third party products listed in the 3Com software product documentation or specifications as being compatible, 3Com will make reasonable efforts to provide compatibility, except where the non-compatibility is caused by a "bug" or defect in the third party's product or from use of the software product not in accordance with 3Com's published specifications or user manual.

THIS 3COM PRODUCT MAY INCLUDE OR BE BUNDLED WITH (1) THIRD PARTY SOFTWARE, OR (2) 3COM SOFTWARE THAT IS LICENSED "AS IS", THE USE OF WHICH IS GOVERNED BY A SEPARATE END USER LICENSE AGREEMENT. THIS 3COM WARRANTY DOES NOT APPLY TO SUCH THIRD PARTY SOFTWARE OR 3COM SOFTWARE LICENSED "AS IS". FOR THE APPLICABLE WARRANTY, PLEASE REFER TO THE END USER LICENSE AGREEMENT GOVERNING THE USE OF SUCH SOFTWARE OR THE ACCOMPANYING DOCUMENTATION RELATING TO SUCH SOFTWARE.

YEAR 2000 WARRANTY: In addition to the Hardware Warranty and Software Warranty stated above, 3Com warrants that each product sold or licensed to Customer on and after January 1, 1998 that is date sensitive will continue performing properly with regard to such date data on and after January 1, 2000, provided that all other products used by Customer in connection or combination with the 3Com product, including hardware, software, and firmware, accurately exchange date data with the 3Com product, with the exception of those products identified at 3Com's Web site, <http://www.3com.com/products/yr2000.html>, as not meeting this standard. If it appears that any product that is stated to meet this standard does not perform properly with regard to such date data on and after January 1, 2000, and Customer notifies 3Com within ninety (90) days after purchase of the product from 3Com or its authorized reseller, 3Com shall, at its option and expense, provide a software update which would effect the proper performance of such product, repair such product, deliver to Customer an equivalent product to replace such product, or if none of the foregoing is feasible, refund to Customer the purchase price paid for such product.

Any software update or replaced or repaired product will carry a Year 2000 Warranty for ninety (90) days after purchase.

OBTAINING WARRANTY SERVICE: Customer must contact a 3Com Corporate Service Center or an Authorized 3Com Service Center within the applicable warranty period to obtain warranty service authorization. Dated proof of purchase from 3Com or its authorized reseller may be required. Products returned to 3Com's Corporate Service Center must be pre-authorized by 3Com with a User Service Order (USO) number (or a Return Material Authorization (RMA) number or a Service Repair Order (SRO) number, whichever was issued) marked on the outside of the package, and sent prepaid and packaged appropriately for safe shipment, and it is recommended that they be insured or sent by a method that provides for tracking of the package. Responsibility for loss or damage does not transfer to 3Com until the returned item is received by 3Com. The repaired or replaced item will be shipped to Customer, at 3Com's expense, not later than thirty (30) days after 3Com receives the defective product, and 3Com will retain risk of loss or damage until the item is delivered to Customer.

3Com shall not be responsible for any software, firmware, information, or memory data of Customer contained in, stored on, or integrated with any products returned to 3Com for repair, whether under warranty or not.

Dead- or Defective-on-Arrival. In the event a product completely fails to function or exhibits a defect in materials or workmanship within the first forty-eight (48) hours of installation but no later than thirty (30) days after the date of purchase, and this is verified by 3Com, it will be considered dead- or defective-on-arrival (DOA) and a replacement shall be provided prior to 3Com receiving the defective product, but only if Customer provides a purchase order number, credit card number, or other method of payment acceptable to 3Com, to be used if 3Com needs to charge Customer for the replacement, as explained below. The replacement product will normally be shipped not later than three (3) business days after 3Com's verification of the DOA product, but may be delayed due to export or import procedures. The

shipment of a replacement product prior to 3Com receiving the defective product is subject to local legal requirements and may not be available in all locations. When such a replacement is provided and Customer fails to return the original product to 3Com within fifteen (15) days after shipment of the replacement, 3Com will charge Customer for the replacement product, at list price.

Shipment of a Replacement Prior to 3Com Receiving the Defective Product is provided for five (5) years, after which time it may be available for a specified fee, but in either case only if Customer provides a purchase order number, credit card number, or other method of payment acceptable to 3Com, to be used if 3Com needs to charge Customer for the replacement, as explained below. 3Com will make commercially reasonable efforts to ship the replacement product not later than five (5) business days after receiving the request for a replacement, but may be delayed due to product availability or export or import procedures. The shipment of a replacement product prior to 3Com receiving the defective product is subject to local legal requirements and may not be available in all locations. When such a replacement is provided and Customer fails to return the original product to 3Com within fifteen (15) days after shipment of the replacement, 3Com will charge Customer for the replacement, at list price. This replacement prior to 3Com receiving the defective product is different from the fee-based Advance Hardware Replacement Service, which is available as a contracted service offering.

INCLUDED SERVICES:

3Com's Electronic Support Services, available at no charge, include 3Com Knowledgebase, information on known bugs, documentation, release notes, and publicly available software and firmware upgrades. 3Com reserves the right to modify or cancel this offering at any time, without advance notice.

Telephone Technical Support, with coverage for basic troubleshooting only, will be provided at no additional charge for 12 months from the date of purchase, on a commercially reasonable efforts basis. Telephone support is provided by 3Com only if Customer purchased this product directly from 3Com, or if Customer's reseller is unable to provide telephone support. To qualify for this telephone technical support, Customer must register on the 3Com Web site at <http://support.3com.com/index.htm>, and state the date of purchase, product number, and serial number. 3Com's response to a request for telephone technical support will be in the form of a return call from a 3Com representative by close of business the following business day, defined as 9 a.m. to 5 p.m., local time, Monday through Friday, excluding local holidays. Please refer to the Technical Support appendix in the User Guide for telephone numbers.

Software Updates. All software and firmware upgrades and the latest code for this product downloaded through the 3Com Software Library.

WARRANTIES EXCLUSIVE: IF A 3COM PRODUCT DOES NOT OPERATE AS WARRANTED ABOVE, CUSTOMER'S SOLE REMEDY FOR BREACH OF THAT WARRANTY SHALL BE REPAIR, REPLACEMENT, OR REFUND OF THE PURCHASE PRICE PAID, AT 3COM'S OPTION. TO THE FULL EXTENT ALLOWED BY LAW, THE FOREGOING WARRANTIES AND REMEDIES ARE EXCLUSIVE AND ARE IN LIEU OF ALL OTHER WARRANTIES, TERMS, OR CONDITIONS, EXPRESS OR IMPLIED, EITHER IN FACT OR BY OPERATION OF LAW, STATUTORY OR OTHERWISE, INCLUDING WARRANTIES, TERMS, OR CONDITIONS OF MERCHANTABILITY, FITNESS FOR A PARTICULAR PURPOSE, SATISFACTORY QUALITY, CORRESPONDENCE WITH DESCRIPTION, AND NON-INFRINGEMENT, ALL OF WHICH ARE EXPRESSLY DISCLAIMED. 3COM NEITHER ASSUMES NOR AUTHORIZES ANY OTHER PERSON TO ASSUME FOR IT ANY OTHER LIABILITY IN CONNECTION WITH THE SALE, INSTALLATION, MAINTENANCE OR USE OF ITS PRODUCTS.

3COM SHALL NOT BE LIABLE UNDER THIS WARRANTY IF ITS TESTING AND EXAMINATION DISCLOSE THAT THE ALLEGED DEFECT OR MALFUNCTION IN THE PRODUCT DOES NOT EXIST OR WAS CAUSED BY CUSTOMER'S OR ANY THIRD PERSON'S MISUSE, NEGLIGENCE, IMPROPER INSTALLATION OR TESTING, UNAUTHORIZED ATTEMPTS TO OPEN, REPAIR OR MODIFY THE PRODUCT, OR ANY OTHER CAUSE BEYOND THE RANGE OF THE INTENDED USE, OR BY ACCIDENT, FIRE, LIGHTNING, POWER CUTS OR OUTAGES, OTHER HAZARDS, OR ACTS OF GOD.

LIMITATION OF LIABILITY: TO THE FULL EXTENT ALLOWED BY LAW, 3COM ALSO EXCLUDES FOR ITSELF AND ITS SUPPLIERS ANY LIABILITY, WHETHER BASED IN CONTRACT OR TORT (INCLUDING NEGLIGENCE), FOR INCIDENTAL, CONSEQUENTIAL, INDIRECT, SPECIAL, OR PUNITIVE DAMAGES OF ANY KIND, OR FOR LOSS OF REVENUE OR PROFITS, LOSS OF BUSINESS, LOSS OF INFORMATION OR DATA, OR OTHER FINANCIAL LOSS ARISING OUT OF OR IN CONNECTION WITH THE SALE, INSTALLATION, MAINTENANCE, USE, PERFORMANCE, FAILURE, OR INTERRUPTION OF ITS PRODUCTS, EVEN IF 3COM OR ITS AUTHORIZED RESELLER HAS BEEN ADVISED OF THE POSSIBILITY OF SUCH DAMAGES, AND LIMITS ITS LIABILITY TO REPAIR, REPLACEMENT, OR REFUND OF THE PURCHASE PRICE PAID, AT 3COM'S OPTION. THIS DISCLAIMER OF LIABILITY FOR DAMAGES WILL NOT BE AFFECTED IF ANY REMEDY PROVIDED HEREIN SHALL FAIL OF ITS ESSENTIAL PURPOSE.

DISCLAIMER: Some countries, states, or provinces do not allow the exclusion or limitation of implied warranties or the limitation of incidental or consequential damages for certain products supplied to consumers, or the limitation of liability for personal injury, so the above limitations and exclusions may be limited in their application to you. When the implied warranties are not allowed to be excluded in their entirety, they will be limited to the duration of the applicable written warranty. This warranty gives you specific legal rights which may vary depending on local law.

GOVERNING LAW: This Limited Warranty shall be governed by the laws of the State of California, U.S.A., and by the laws of the United States, excluding their conflicts of laws principles. The United Nations Convention on Contracts for the International Sale of Goods is hereby excluded in its entirety from application to this Limited Warranty.

3Com Corporation
5400 Bayfront Plaza
P.O. Box 58145
Santa Clara, CA 95052-8145
(408) 326-5000
January 2001

3Com reserves the right to modify or cancel this offering at any time, without advance notice. This offering is not available where prohibited or restricted by law.

TECHNICAL SUPPORT

The following options are available for technical support:

- In the first instance contact your Network Supplier
- Check the 3Com knowledgebase at <http://knowledgebase.3com.com>
- Browse the 3Com web site on <http://www.3com.com>

Please have your product model name, part number, hardware revision number and serial number along with all relevant details of the problem to hand before calling your Network Supplier or 3Com on the numbers below.

Country	Telephone Number	Country	Telephone Number
Asia, Pacific Rim			
Australia	1 800 678 515	Philippines	1235 61 266 2602
Hong Kong	800 933 486	P.R. of China	10800 61 00137 or 021 6350 1590 or 00800 0638 3266
India	+61 2 9937 5085 or 0008006501111	Singapore	800 6161 463
Indonesia	001 800 61 009	S. Korea	00798 611 2230
Japan	03 5783 1270	From anywhere in S. Korea:	(0)2 3455 6455
Malaysia	1800 801 777	From Seoul:	0080 611 261
New Zealand	0800 446 398	Taiwan, R.O.C.	001 800 611 2000
Pakistan	+61 2 9937 5083	Thailand	
Europe, Middle East and Africa			
From anywhere in these regions, call:	+44 (0) 1442 435529 phone +44 (0) 1442 436722 fax		
Europe and South Africa: From the following countries, you may use the toll-free numbers:			
Austria	0800 297468	Luxembourg	0800 3625
Belgium	0800 71429	Netherlands	0800 0227788
Denmark	800 17309	Norway	800 11376
Finland	0800 113153	Poland	00800 3111206
France	0800 917959	Portugal	0800 831416
Germany	0800 1821502	South Africa	0800 995014
Hungary	06800 12813	Spain	900 983125
Ireland	1800 553117	Sweden	020 795482
Israel	1800 9453794	Switzerland	0800 55 3072
Italy	800 8 79489	U.K.	0800 966197
Latin America			
Brazil	0800 13 3266	Puerto Rico	800 666 5065
Mexico	01 800 849CARE	Central and South America	AT&T +800 998 2112
North America			
	1 800 NET 3Com (1 800 638 3266) Enterprise Customers: 1 800 876 3266		

REGULATORY NOTICES

FCC Statement

This equipment has been tested and found to comply with the limits for a Class A digital device, pursuant to part 15 of the FCC rules. These limits are designed to provide reasonable protection against harmful interference when the equipment is operated in a commercial environment. This equipment generates, uses and can radiate radio frequency energy and, if not installed and used in accordance with the instructions, may cause harmful interference to radio communications. Operation of this equipment in a residential area is likely to cause harmful interference to radio communications, in which case the user will be required to correct the interference at their own expense.

Information To The User

If this equipment does cause interference to radio or television reception, which can be determined by turning the equipment off and on, the user is encouraged to try to correct the interference by one or more of the following measures:

- Reorient the receiving antenna.
- Relocate the equipment with respect to the receiver.
- Move the equipment away from the receiver.
- Plug the equipment into a different outlet so that equipment and receiver are on different branch circuits.

If necessary, the user should consult the dealer or an experienced radio/television technician for additional suggestions. The user may find the following booklet prepared by the Federal Communications Commission helpful:

How to Identify and Resolve Radio-TV Interference Problems

This booklet is available from the U.S. Government Printing Office, Washington, DC 20402, Stock No. 004-000-00345-4.

In order to meet FCC emissions limits, this equipment must be used only with cables which comply with IEEE 802.3.

CE Statement (Europe)

This product complies with the European Low Voltage Directive 73/23/EEC and EMC Directive 89/336/EEC as amended by European Directive 93/68/EEC.

CSA Statement

This Class A digital apparatus meets all requirements of the Canadian Interference-Causing Equipment Regulations.

Cet appareil numérique de la classe A respecte toutes les exigences du Règlement sur le matériel brouilleur du Canada.

VCCI Statement

この装置は、情報処理装置等電波障害自主規制協議会（VCCI）の基準に基づくクラスB情報技術装置です。この装置は、家庭環境で使用することを目的としていますが、この装置がラジオやテレビジョン受信機に近接して使用されると、受信障害を引き起こすことがあります。

取扱説明書に従って正しい取り扱いをして下さい。

BSMI Statement

警告使用者：這是甲類的資訊產品，在居住的環境中使用時，可能會造成射頻干擾，在這種情況下，使用者會被要求採取某些適當的對策。

LEGAL NOTICES

© 3Com Technologies, 2001. All rights reserved. No part of this documentation may be reproduced in any form or by any means or used to make any derivative work (such as translation, transformation, or adaptation) without permission from 3Com Technologies.

3Com Technologies reserves the right to revise this documentation and to make changes in content from time to time without obligation on the part of 3Com Technologies to provide notification of such revision or change.

3Com Technologies provides this documentation without warranty of any kind, either implied or expressed, including, but not limited to, the implied warranties of merchantability and fitness for a particular purpose. 3Com may make improvements or changes in the product(s) and/or the program(s) described in this documentation at any time.

UNITED STATES GOVERNMENT LEGENDS:

If you are a United States government agency, then this documentation and the software described herein are provided to you subject to the following restricted rights:

For units of the Department of Defense:

Restricted Rights Legend: Use, duplication or disclosure by the Government is subject to restrictions as set forth in subparagraph (c) (1) (ii) for restricted Rights in

Technical Data and Computer Software clause at 48 C.F.R. 52.227-7013. 3Com Centre, Boundary Way, Maylands Park South, Hemel Hempstead, Herts, HP2 7YU, U.K.

For civilian agencies:

Restricted Rights Legend: Use, reproduction or disclosure is subject to restrictions set forth in subparagraph (a) through (d) of the Commercial Computer Software - Restricted Rights Clause at 48 C.F.R. 52.227-19 and the limitations set forth in 3Com Corporation's standard commercial agreement for the software. Unpublished rights reserved under the copyright laws of the United States.

If there is any software on removable media described in this documentation, it is furnished under a license agreement included with the product as a separate document, in the hard copy documentation, or on the removable media in a directory file named LICENSE.TXT. If you are unable to locate a copy, please contact 3Com and a copy will be provided to you.

Unless otherwise indicated, 3Com registered trademarks are registered in the United States and may or may not be registered in other countries.

3Com and SuperStack are registered trademarks of 3Com Corporation.

Other brand and product names may be registered trademarks or trademarks of their respective holders.

ENVIRONMENTAL STATEMENTS

General Environmental Statement

It is the policy of 3Com Corporation to be environmentally friendly in all operations. To uphold our policy, we are committed to:

- Establishing environmental performance standards that comply with national legislation and regulations
- Conserving energy, materials and natural resources in all operations
- Reducing the waste generated by all operations
- Ensuring that all waste conforms to recognized environmental standards
- Maximizing the recyclable and reusable content of all products
- Ensuring that all products can be recycled, reused and disposed of safely
- Ensuring that all products are labelled according to recognized environmental standards
- Improving our environmental record on a continual basis

End Of Life Statement

3Com processes allow for the recovery, reclamation and safe disposal of all end-of-life electronic components.

Regulated Materials Statement

3Com products do not contain any hazardous or ozone-depleting material.

Environmental Statement about the Documentation

The documentation for this product is printed on paper that comes from sustainable, managed forests; it is fully biodegradable and recyclable, and is completely chlorine-free. The varnish is environmentally-friendly, and the inks are vegetable-based with a low heavy-metal content.

Environmental Statement about the Product Packaging

The packaging for this product is fully recyclable. It has a recycled (post consumer) waste content of at least 40% by weight, and no heavy-metal content.

The SuperStack 3 Baseline Hub is part of the extensive SuperStack 3 range of 3Com products. This range includes hubs, switches, power systems and other networking equipment, and is continually being developed. Contact your supplier for the latest product information and to order these products.

Product Registration

You can now register your SuperStack 3 Hub on the 3Com web site to receive up-to-date information on your product:

<http://www.support.3com.com/registration/frontpg.pl>

Year 2000 Compliance

For information on Year 2000 compliance and 3Com products, visit the 3Com Year 2000 Web page:

<http://www.3com.com/products/yr2000.html>

Feedback

Your suggestions are very important to us. They will help make our documentation more useful to you. Please e-mail comments about this document to 3Com at:

pddtechpubs_comments@3com.com

Please include the following information when commenting: the document title, part number (shown at the bottom of page 8), and page number, if appropriate.