



22-INCH PREMIUM FLAT COLOR MONITOR X7149A and X7149A-STH

User's Manual

Bedienungsanleitung

Manual del usuario

Manuel de Utilisateur

Manuale Utente

Bruksanvisning

ユーザーズマニュアル

用戶手冊

用戶手冊

사용설명서



Safety Instruction	English-1
Warning	English-1
Caution	English-1
Unpacking the Flat Color Monitor	English-2
Contents	English-3
Front Panel Overview	English-4
Back Panel Overview	English-5
Quick Start	English-6
Controls	English-7
Recommended use	English-10
Specifications	English-12
Features	English-13
Monitor Troubleshooting	English-14
TCO'99	English-15

Safety Instruction



WARNING



TO PREVENT FIRE OR SHOCK HAZARDS, DO NOT EXPOSE THIS UNIT TO RAIN OR MOISTURE. ALSO, DO NOT USE THIS UNIT'S POLARIZED PLUG WITH AN EXTENSION CORD RECEPTACLE OR OTHER OUTLETS UNLESS THE PRONGS CAN BE FULLY INSERTED.

REFRAIN FROM OPENING THE CABINET AS THERE ARE HIGH VOLTAGE COMPONENTS INSIDE. REFER SERVICING TO QUALIFIED SERVICE PERSONNEL.



CAUTION

RISK OF ELECTRIC SHOCK • DO NOT OPEN



CAUTION: TO REDUCE THE RISK OF ELECTRIC SHOCK, DO NOT REMOVE COVER (OR BACK). NO USER SERVICEABLE PARTS INSIDE. REFER SERVICING TO QUALIFIED SERVICE PERSONNEL.



This symbol warns user that uninsulated voltage within the unit may have sufficient magnitude to cause electric shock. Therefore, it is dangerous to make any kind of contact with any part inside this unit.



This symbol alerts the user that important literature concerning the operation and maintenance of this unit has been included. Therefore, it should be read carefully in order to avoid any problems.

Canadian Department of Communications Compliance Statement

DOC: This Class B digital apparatus meets all requirements of the Canadian Interference-Causing Equipment Regulations.

C-UL: Bears the C-UL Mark and is in compliance with Canadian Safety Regulations according to CSA C22.2 #950.

FCC Information

1. Use the attached specified cables with the color monitor so as not to interfere with radio and television reception.
 - (1) Please use the supplied power cable or equivalent to ensure FCC compliance.
 - (2) Shielded video type signal cable.Use of other cables and adapters may cause interference with radio and television reception.
2. This equipment has been tested and found to comply with the limits for a Class B digital device, pursuant to part 15 of the FCC Rules. These limits are designed to provide reasonable protection against harmful interference in a residential installation. This equipment generates, uses, and can radiate radio frequency energy, and, if not installed and used in accordance with the instructions, may cause harmful interference to radio communications. However, there is no guarantee that interference will not occur in a particular installation. If this equipment does cause harmful interference to radio or television reception, which can be determined by turning the equipment off and on, the user is encouraged to try to correct the interference by one or more of the following measures:
 - Reorient or relocate the receiving antenna.
 - Increase the separation between the equipment and receiver.
 - Connect the equipment into an outlet on a circuit different from that to which the receiver is connected.
 - Consult your dealer or an experienced radio/TV technician for help.

If necessary, the user should contact the dealer or an experienced radio/television technician for additional suggestions. The user may find the following booklet, prepared by the Federal Communications Commission, helpful: "How to Identify and Resolve Radio-TV Interference Problems." This booklet is available from the U.S. Government Printing Office, Washington, D.C., 20402, Stock No. 004-000-00345-4.

No user serviceable parts inside. Do not attempt to modify this equipment. If modified, your authority to operate this equipment might be voided by FCC.

ENERGY STAR® is a U.S. registered trademark. All other brands and product names are trademarks or registered trademarks of their respective owners.

As an **ENERGY STAR** Partner, Sun Microsystems, Inc. have determined that this product meets the **ENERGY STAR** guidelines for energy efficiency.

The **ENERGY STAR** emblem does not represent EPA endorsement of any product or service. All other trademarks mentioned in this manual are the property of their respective owners.

Unpacking the Flat Color Monitor

Carefully unpack the flat color monitor from the packing carton. Your flat color monitor configuration might not contain all the components shown.

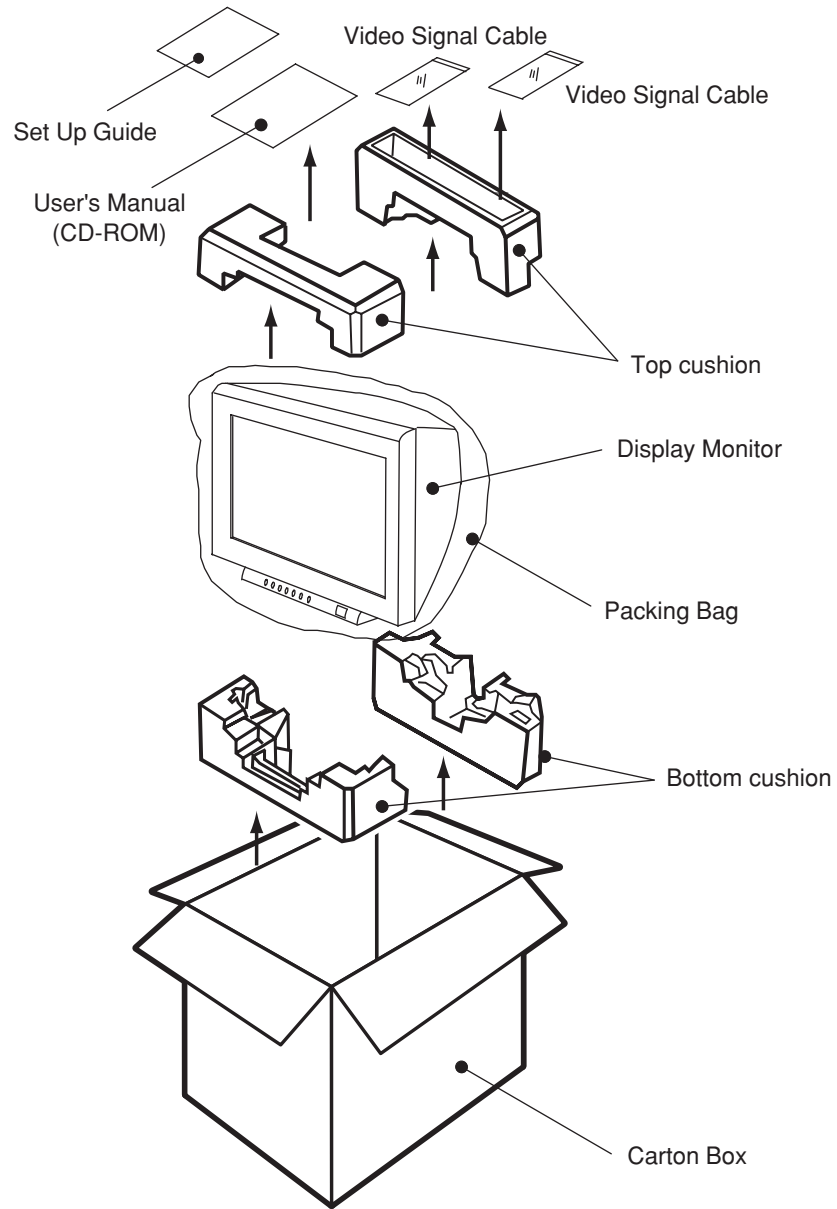
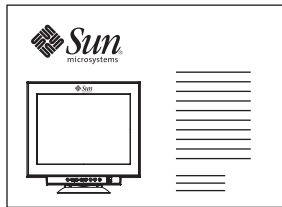

FIGURE 1-1 Unpacking the Flat Color Monitor

Contents

Your new display box* should contain the following:

- Display with tilt/swivel base
- User's Manual (CD-ROM)
- Set Up Guide
- Video Signal Cable (D-Sub to D-Sub)
- Video Signal Cable (D-Sub to DVI-A)



Set Up Guide

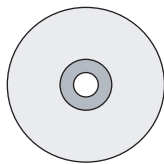

User's Manual (CD-ROM)

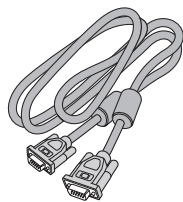

Video Signal Cable
(D-Sub to D-Sub)

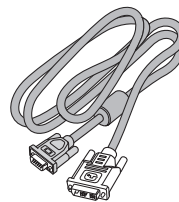

Video Signal Cable
(D-Sub to DVI-A)

* Remember to save your original box and packing material to transport or ship the monitor.

Front Panel Overview

The following numbered list corresponds to the numeric captions in FIGURE 1-2.

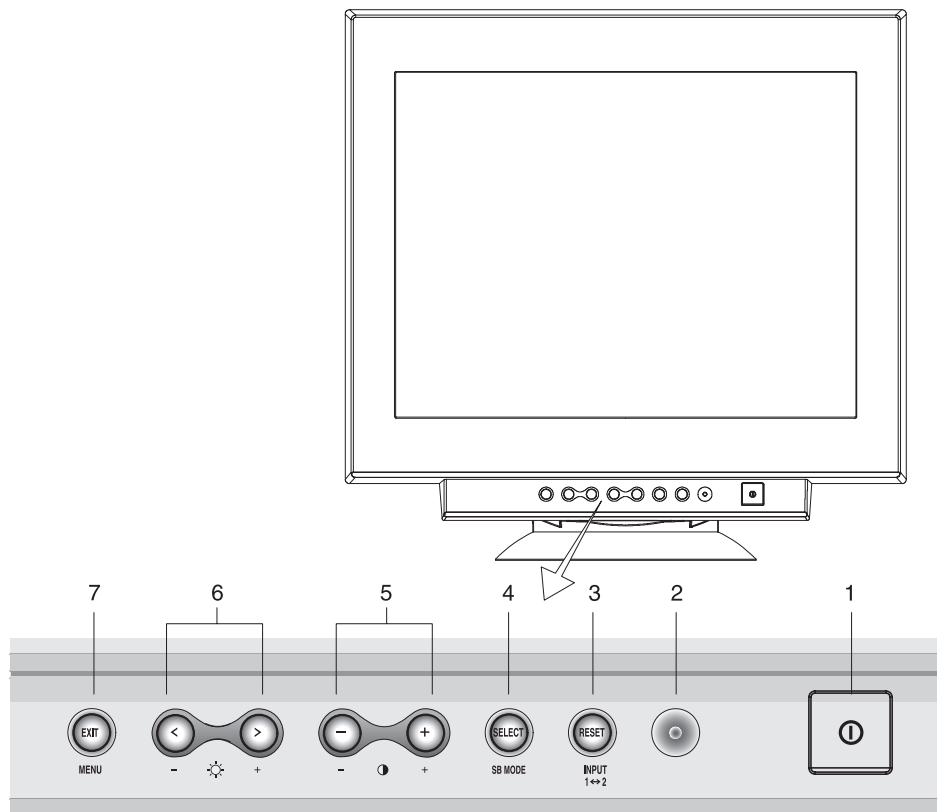

FIGURE 1-2 Front Panel Overview

1. Power switch
2. Power-indicator LED
3. RESET/INPUT 1 ↔ 2 button
4. SELECT/SB MODE button
5. CONTROL (CONTRAST/adjust) +/- button
6. CONTROL (BRIGHTNESS/navigation) < > button
7. EXIT/MENU button

Back Panel Overview

The following numbered list corresponds to the numeric captions in FIGURE 1-3.

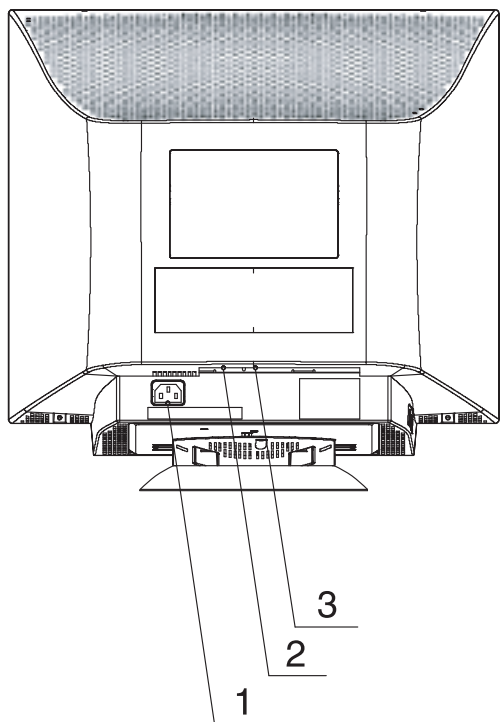

FIGURE 1-3 Back Panel Overview

- 1. AC Input Connector
- 2. INPUT (D-SUB1) Connector
- 3. INPUT (D-SUB2) Connector

Quick Start

To attach the monitor to your system, follow these instructions:

1. Turn off the power to your computer.
 2. Connect one end of the signal cable to the connector of the display card in your system (**FIGURE 1-4**).
Tighten all screws.
 3. Connect the other end of signal cable connector on the back of the monitor.
NOTE: Incorrect cable connections may result in irregular operation, damage display quality/components of CRT monitor.
 4. Connect one end of the power cord to the AC inlet on the back of the monitor and the other end to the power outlet (**FIGURE 1-5**).
 5. Turn on the monitor (**FIGURE 1-6**).
 6. Turn on the Computer.
- NOTE:** If you have any problems, please refer to the **Troubleshooting** section of this User's Manual.



FIGURE 1-4

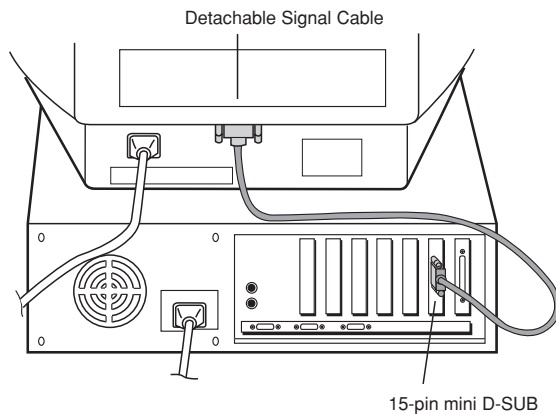

FIGURE 1-5

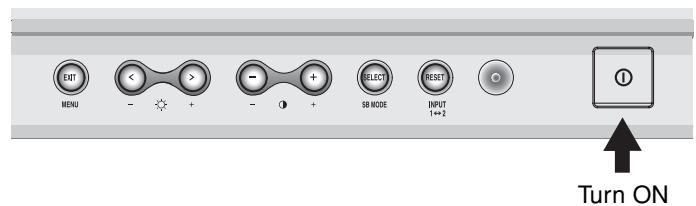

FIGURE 1-6

Controls

OSD (On-Screen Display) control buttons on the front of the monitor function as follows:

	Main Menu	Sub-Menu
EXIT	Exits the OSD menu.	Exits to the OSD controls main menu.
	Note : Deactivates the OSD menu and activates the OSD menu when the OSD is turned off.	
CONTROL ◀ / ▶	Moves the highlighted area left/right to select one of the sub-menu.	Moves the highlighted area left/right to select one of the controls.
	Note : When the OSD menu is off, it acts as a Hot key for Brightness .	
CONTROL +/-	Has no function	Moves the bar in the – or + direction to decrease or increase the adjustment.
	Note : When the OSD menu is off, it acts as a Hot Key for Contrast .	
SELECT/ SB MODE	Enters sub-menu.	Has no function.
	When the OSD is off, it will act as the SuperBright (SB) function key. User can select between SB MODE OFF, SB MODE1, and SB MODE2. The first time this key is pressed, the current SB Mode is indicated. Within a 3 second window, if this key is selected again, the SB MODE will change to the next SB MODE. For example, the current mode is SB MODE OFF, the key is pressed twice within a 3 second time frame, the SB MODE will change to SB MODE1 and so on. The color temperature at each SB Mode is adjusted by appropriate color control except for the sRGB mode whose color setting cannot be adjusted. When the unit is turned off, it will reset to SB off mode.	
RESET/ INPUT 1 ↔ 2	Resets all the controls within the highlighted menu to the factory setting.	Resets the highlighted control to the factory setting.
	Note : Acts as Hot Key for input connector (INPUT 1 ↔ 2).	
	Note : When RESET is pressed in the main and sub-menu, a warning window will appear allowing you to select the reset function.	



Brightness/Contrast Controls

Brightness: Adjusts the overall image and background screen brightness.

Contrast: Adjusts the image brightness in relation to the background.

Degauss: Eliminates the buildup of stray magnetic fields which alter the correct scan of the electron beams and affect the purity of the screen colors, focus and convergence. When activated, your screen image will jump and waver a bit as the screen is demagnetized.

NOTE: Please allow a minimum of 20 minutes to elapse between uses of the Degauss Control.

Constant Brightness: Sustains the brightness and screen color levels consistently over the normal life of the monitor. The **Constant Brightness** function requires a 30 minute warm-up of the monitor before the feature is fully functional.



Size and Position Controls

Auto Adjust: Automatically adjust the horizontal and vertical size and position settings for the applicable timing signal.

NOTE: **Auto Adjust** is unavailable with no image signal or narrow size of image signal input.

Left/Right: Moves the image horizontally (left or right).

Down/Up: Moves the image vertically (up or down).

Narrow/Wide: Decreases or increases the horizontal size of the image.

Short/Tall: Decreases or increases the vertical size of the image.



Color Control System

Color presets 1 through 5 select the desired color setting. The bar is replaced by the color setting choice from 1, 2, 3, sRGB, 5. Each color setting is adjusted at the factory to the stated Kelvin degrees. If a setting is adjusted, the name of the setting will change from Kelvin to Custom.

NOTE: Selecting sRGB does not allow you to adjust each color.

Red, Green, Blue: Color Control System decreases or increases the monitor's red, green or blue color guns depending upon which is selected. The change in color will appear on screen and the direction (decrease or increase) will be shown by the bars.

NOTE: sRGB does not allow you to control the Color, Brightness and Contrast.



Geometry Controls

Geometry Controls Menu

The **Geometry** controls allow you to adjust the curvature or angle of the sides of your display.

In/Out (pincushion): Decreases or increases the curvature of the sides either inward or outward.

Left/Right (pincushion balance): Decreases or increases the curvature of the sides either to the left or right.

Tilt (parallelogram): Decreases or increases the tilt of the sides either to the left or right.

Align (trapezoidal): Decreases or increases the bottom of the screen to be the same as the top.

Rotate (raster rotation): Rotates the entire display clockwise or counterclockwise.

Corner Correction: Allows you to adjust the geometry of the corners of your display — **Top, Top Balance, Bottom or Bottom Balance.**



Tools 1

Moiré Canceled: Moiré is a wavy pattern which can sometimes appear on the screen. The pattern is repetitive and superimposed as rippled images. When running certain applications, the wavy pattern is more evident than in others. To reduce moiré, adjust the level by using the **-/+** CONTROL buttons.

Convergence: Aligns all three colors (R,G,B) to form a single color (white). The purpose of this control is to ensure that a white line drawn on the screen is as crisp and clear as possible.

- Use the **CONVERGENCE (HOR.)** control to adjust the alignment of the white lines in the left/right direction.
- Use the **CONVERGENCE (VER.)** control to adjust the alignment of the white lines in the up/down direction.
- Use the **V-CONVERGENCE-TOP** control to adjust the alignment of the top area of the white line in the up/down direction.
- Use the **V-CONVERGENCE-BOTTOM** control to adjust the alignment of the bottom area of the white line in the up/down direction.

Linearity: This selection allows you to adjust the spacing of the area on the screen. The purpose of this control is to ensure that a one-inch circle is a true one-inch circle wherever it is on the screen. The best way to determine the vertical linearity is as follows:

- Draw equally spaced horizontal lines using a drawing application that has a ruler.
- Use the **Vertical Balance** control to adjust the lines near the top and bottom of your screen.
- Use the **LINEARITY (VER.)** control to adjust the spacing between the lines near the center and top of your screen.

Corner Purity Control: Eliminates picture impurities that may result from the earth's magnetic field. While in the sub-menus (**TL:** Top Left, **TR:** Top Right, **BL:** Bottom Left, **BR:** Bottom Right or **L/R:** Left/Right, use the **-/+** control buttons to fine tune the Corner Purity corrections.

NOTE: We recommend that you perform Corner Purity correction while running a typical application such as a spreadsheet or text document.

Tools 2

Language: OSD control menus are available in 6 languages.

OSD Position: You can choose where you would like the OSD control menu to appear on your screen. Selecting OSD Position allows you to manually adjust the OSD control menu left, right, up or down.

OSD Turn Off: The OSD control menu will stay on as long as it is in use. In the OSD Turn Off sub-menu, you can select how long the monitor waits after the last touch of a button for the OSD control menu to disappear. The preset choice is in 5 seconds step between 5–120 seconds.

OSD Lock Out: This control completely locks out access to all OSD control functions except Brightness and Contrast. When attempting to activate OSD control while in the lock out mode, a screen will appear indicator that OSD control are locked out. To activate the OSD Lock Out function, press **SELECT**, then press + and hold down simultaneously. Only **BRIGHTNESS** icon and **CONTRAST** icon are indicated after this action.

To deactivate the OSD Lock Out, press **SELECT**, then press + and hold down simultaneously. OSD control indicator returns to normal OSD after this action.

Off Mode: Enable: The Off Mode works normally and all stages of energy savings are utilized.
Disable: Power savings function is disable.

NOTE: For standard systems and graphics boards, keep the factory setting at ENABLE.

NOTE: Don't keep the monitor on when 'No Signal' is displayed. This could cause image burn in on the screen due to the 'No Signal' message being displayed.

Clamp Pulse Position Control: Operating your monitor at a nonstandard timing may cause images to appear darker than normal or have color distortion. Use of the Clamp Pulse Position control will adjust images to their normal state.

Hot Key: This selection allows you to use ◀ / ▶ as brightness control and –/+ as contrast control.

Factory Preset: Selecting Factory Preset allows you a reset most OSD control settings back to the factory settings. A warning statement will appear to confirm that you do want to reset ALL settings. Individual settings can be reset by highlighting the control to be reset and pressing the **RESET** button.

Information

Display Mode: Indicates the current mode and frequency setting of the monitor.

Monitor Info: Indicates the model and serial numbers of your monitor.

Recommended use

Safety Precautions and Maintenance



FOR OPTIMUM PERFORMANCE, PLEASE NOTE THE FOLLOWING WHEN SETTING UP AND USING THE COLOR MONITOR:



- **DO NOT OPEN THE MONITOR.** There are no user serviceable parts inside and opening or removing covers may expose you to dangerous shock hazards or other risks. Refer all servicing to qualified service personnel.
- Do not spill any liquids into the cabinet or use your monitor near water.
- Do not insert objects of any kind into the cabinet slots, as they may touch dangerous voltage points, which can be harmful or fatal or may cause electric shock, fire or equipment failure.
- Do not place any heavy objects on the power cord. Damage to the cord may cause shock or fire.
- Do not place this product on a sloping or unstable cart, stand or table, as the monitor may fall, causing serious damage to the monitor.
- Keep the monitor away from high capacity transformers, electric motors and other devices such as external speakers or fans, which may create strong magnetic fields.
- If possible, position the monitor so that it is facing the east to minimize the effects of the earth's magnetic field.
- Changing the direction of the monitor while it is powered on may cause image discoloration. To correct this, turn the monitor off for 20 minutes before powering it back on.
- When operating the monitor with its AC 100-120/220-240V worldwide power supply, use a power supply cord that matches the power supply voltage of the AC power outlet being used. The power supply cord you use must have been approved by and comply with the safety standards of your country. (Type H05VV-F 3G 0.7 mm² should be used in Europe)
- In UK, use a BS-approved power cord with molded plug having a black (5A) fuse installed for use with this monitor. If a power cord is not supplied with this monitor, please contact your supplier.

Immediately unplug your monitor from the wall outlet and refer servicing to qualified service personnel under the following conditions:

- When the power supply cord or plug is damaged.
- If liquid has been spilled, or objects have fallen into the monitor.
- If the monitor has been exposed to rain or water.
- If the monitor has been dropped or the cabinet damaged.
- If the monitor does not operate normally by following operating instructions.
- Allow adequate ventilation around the monitor so that heat can properly dissipate. Do not block ventilated openings or place the monitor near a radiator or other heat sources. Do not put anything on top of monitor.
- The power cable connector is the primary means of detaching the system from the power supply. The monitor should be installed close to a power outlet which is easily accessible.
- Handle with care when transporting. Save packaging for transporting.



CAUTION



CORRECT PLACEMENT AND ADJUSTMENT OF THE MONITOR CAN REDUCE EYE, SHOULDER AND NECK FATIGUE. CHECK THE FOLLOWING WHEN YOU POSITION THE MONITOR:



- Adjust the monitor height so that the top of the screen is at or slightly below eye level. Your eyes should look slightly downward when viewing the middle of the screen.
- Position your monitor no closer than 40 cm (16 inches) and no further away than 70 cm (28 inches) from your eyes. The optimal distance is 60 cm (24 inches).
- Rest your eyes periodically by focusing on an object at least 6 m away. Blink often.
- Position the monitor at a 90° angle to windows and other light sources to minimize glare and reflections. Adjust the monitor tilt so that ceiling lights do not reflect on your screen.
- If reflected light makes it hard for you to see your screen, use an anti-glare filter.

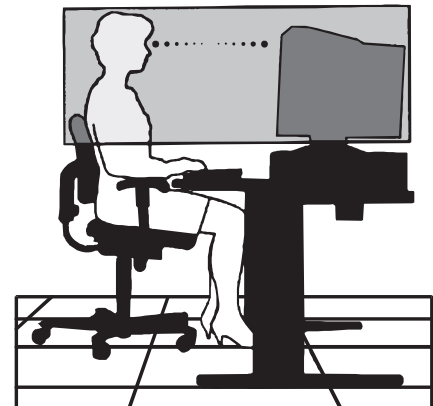

- Clean your monitor

A special coating is provided on the glass (CRT) surface of this monitor to reduce a reflection and static electricity on the glass surface.

Due to the delicate coating on the glass surface, use a lint-free, nonabrasive cloth (cotton or equivalent) and a non-alcohol, neutral, nonabrasive cleaning solution to minimize dust. If the screen requires more than a light cleaning, apply water or soft neutral detergent with much water directly to a soft cloth and use it upon wringing water, to clean the glass surface.

CAUTION: The following agents will cause damage to the CRT when cleaning the glass surface: Benzene, thinner, acid/alkaline detergent, alcohol detergent, detergent with abrasive powder, detergent with antistatic agent, detergent for cleaning.

- Adjust the monitor's brightness and contrast controls to enhance readability.
- Use a document holder placed close to the screen.
- Position whatever you are looking at most of the time (the screen or reference material) directly in front of you to minimize turning your head while you are typing.
- Get regular eye checkups.

Ergonomics

To realize the maximum ergonomics benefits, we recommend the following:

- Adjust the Brightness until the background raster disappears
- Do not position the Contrast control to its maximum setting
- Use the preset Size and Position controls with standard signals
- Use the preset Color Setting and Sides Left/Right controls
- Use non-interlaced signals with a vertical refresh rate between 75-160Hz
- Do not use primary color blue on a dark background, as it is difficult to see and may produce eye fatigue due to insufficient contrast

Specifications

Monitor Specifications		Notes
Picture Tube	Diagonal: 22 inch/550 mm Viewable Image Size: 20 inch/508 mm Radius: 50000 mm	90° deflection, 0.24 mm grille pitch, medium short persistence phosphor, aperture grille CRT, G-WARAS coating
Input Signal	Video: ANALOG 0.7 Vp-p/75 Ohms Sync: Separate sync. TTL Level Horizontal sync. Positive/Negative Vertical sync. Positive/Negative Composite sync. (Negative) (TTL Level) Sync on Green video (Positive) 0.7 Vp-p and sync Negative 0.3 Vp-p	
Display Colors	Analog input: Unlimited number of Colors	Depends on display card used.
Synchronization Range	Horizontal: 30 kHz to 140 kHz Vertical: 50 Hz to 160 Hz	Automatically Automatically
Resolutions Supported Resolution based on horizontal and vertical frequencies only	1024 x 768 @ 75 Hz 1152 x 900 @ 66 Hz 1152 x 900 @ 76 Hz 1280 x 1024 @ 75 Hz 1280 x 1024 @ 76 Hz 1280 x 1024 @ 112 Hz 1600 x 1200 @ 75 Hz This resolution is recommended for optimal display performance. 2048 x 1536 @ 75 Hz	
Active Display Area (Factory Setting)	Horizontal: 396 mm/15.6 inches Vertical: 297 mm/11.7 inches	Dependent upon signal timing used, and does not include border area.
Active Display Area (Full Scan)	406 mm/16.0 inches 304.6 mm/12.0 inches	Dependent upon signal timing used, and does not include border area.
Power Supply Current Rating	AC 100-120 V/220-240 V, 50/60 Hz 1.35A @ 100-120 V / 0.65A @ 220-240 V	
Dimensions	495 mm (W) x 486 mm (H) x 477 mm (D) 19.5 inches (W) x 19.1 inches (H) x 18.8 inches (D)	
Weight	29.3 kg 64.6 lbs	
Environmental Considerations	Operating Temperature: +5°C to +35°C/+41°F to +90°F Humidity: 10% to 90% Storage Temperature: -20°C to +60°C/-4°F to +140°F Humidity: 10% to 90%	
Regulations	Safety: UL1950 (UL) , CSA C22.2 No.950 (c-UL), EN60950 (TÜV-GS) CCC, KETI EMC: FCC Class-B, DOC Class-B, EN55022 Class-B, VCCI Class-B, EN61000-3-2, EN61000-3-3, EN55024 CCC, MIC, BSMI X-Ray: DHHS, HWC, Röv vom 8.1, 1987 Other: CE-Marking, MPR-II/TCO'91 ISO9241-3, ISO9241-7, ISO9241-8 TCO'99 International ENERGY STAR Program	

Features

Flat Aperture Grille CRT: Delivers an unparalleled viewing experience with a virtually flat image, eliminating distortion and reducing glare so that what you see on-screen is what you get on your printed output. The striped phosphor alignment of the CRT delivers superior vertical definition with improved brightness for more uniform image contrast.

Screen Surface: Reduces reflection and glare and increases contrast without sacrificing focus level, clarity or brightness. Along with the flat square technology CRT, a high contrast screen with 0.24mm grille pitch delivers crisp, clean text and graphics.

Dual Dynamic Beam Focus: Provides precise, continuous focus adjustments of the electron beams resulting in optimum image quality, even to the far edges of the screen.

Color Control System: Allows you to change between five color settings on your display to match your personal preference.

OSD (On-Screen Display) Controls: Allow you to quickly and easily adjust all elements of your screen image via simple to use on-screen menus.

Design Features: Enhance human ergonomics to improve the working environment, protect the health of the user and save money. Examples include OSD controls for quick and easy image adjustments, tilt/swivel base for preferred angle of vision and compliance with MPRII guidelines for lower emissions.

Plug and Play: Support of VESA DDC 2B and CI facilitates setup and installation by allowing the monitor to send its capabilities (such as screen size and resolutions supported) directly to your computer, automatically optimizing display performance.

Off Mode System: Provides innovative power-saving methods that allow the monitor to shift to a lower power consumption level when on but not in use, saving two-thirds of your monitor energy costs, reducing emissions and lowering the air conditioning costs of the workplace.

Reduced Magnetic Field Technology: Reduces magnetic and alternating electric field emissions and static electricity, addressing ergonomic concerns regarding potential risks from extended computer monitor use.

Multiple Frequency Technology: Automatically adjusts monitor to the display card's scanning frequency, thus displaying the resolution required.

Full Scan Capability: Allows you to use the entire screen area in most resolutions, significantly expanding image size.

Corner Purity Control: The unique design automatically eliminates picture impurities that may result from stray magnetic fields (including the earth's permanent magnets, etc.) and now allows you to easily adjust impurities in the four corners of your monitor.

Convergence Control: Allows you to adjust the horizontal and vertical convergence ensure that a white line drawn on the screen is as crisp and clear as possible.

Auto Adjust: Allows you to easily and quickly adjust and position for Non-preset timing.

GTF Auto Adjust: Automatically adjust horizontal and vertical size and position settings according to GTF standard with the signal timing which Auto Adjust is not available.

Constant Brightness: Sustains the brightness and screen color levels consistently over the normal life of the monitor.

SB (Super Brightness) Mode: Provides the screen brightness suitable for the screen images displayed.

Super Bright Mode OFF: for text based images (normal use)

Super Bright Mode-1 ON: for images

Super bright Mode-2 ON: for moving image such as DVD movies

Monitor Troubleshooting

Self check function

- Press any control button on the front of monitor when you see a problem on the screen.
- In case that all R, G and B colors are seen in the diagnosis message, the monitor has no problem.
- In case that some color is lack in the message, the monitor has a problem. Contact Customer Service.
- In case that no diagnosis message displayed with LED lit in green, power off the computer.
- Check the signal cable and computer in case that the diagnosis message displayed.
- Contact Customer Service in case that the diagnosis message still does not display.
- In case that no diagnosis message displayed with LED lit in orange.
- Check the signal cable and computer.
- Move the mouse or press any key on the keyboard.
- In case that no diagnosis message displayed with LED lit in green and orange.
- Contact Customer Service.

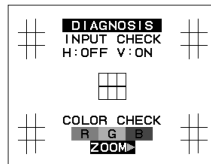

No picture

- Display card should be completely seated in its slot.
- Power Button and computer power switch should be in the ON position.
- Signal cable should be completely connected to display card/computer.
- Check connector for bent or pushed-in pins.

Image is scrolling or unstable

- Signal cable should be completely attached to the computer.
- Check pin assignments and signal timings of the monitor and your display card with respect to recommended timings and pin assignments.

LED on monitor is not lit (no green or orange color can be seen)

- Power Switch should be in the ON position and power cord should be connected.

Picture is fuzzy or color looks blotchy

- If the picture is fuzzy, adjust the Moiré Canceller control. If the color looks blotchy, adjust the Brightness, Contrast or Corner Purity controls, or use the Clamp pulse Position control to change modes.
- Access the Degauss Control through OSD controls. Activate the Degauss Control.

CAUTION: A minimum interval of 20 minutes should elapse before the Degauss Control is used a second time when not switching between modes.

Picture bounces or a wavy pattern is present in the picture

- Move electrical devices that may be causing electrical interference away from the monitor.

Edges of the display image are not square

- Use the OSD Geometry Controls to straighten the edges.
- If possible, position the front of the monitor facing east.

Display image is not centered, too small, or too large

- Use the OSD Size and Position Controls to adjust the image.

Thin horizontal lines appear on your screen

- Thin horizontal lines are normal for an aperture grille CRT and are not a malfunction. These are shadows from the damper wires used to stabilize the aperture grille and are most noticeable when the screen's background is light (usually white).

Black vertical lines are visible on the screen

- Thin vertical black lines on one or both sides of the screen. This minor condition is caused by grille element overlap which can occur during shipping.
- Position an open white window over the affected area of the screen and maximize the brightness and contrast controls. This will cause localized heating of the overlap which will clear in a few minutes. Be sure to readjust the brightness and contrast controls back to the normal viewing level after this procedure.

Attention message displayed

- Check the input signal.

NOTE: The attention message may be displayed when power on the monitor. In case that the attention message disappears after in a little while, there is no problem at the inputted signal.

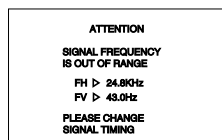

Congratulations! You have just purchased a TCO'99 approved and labeled product! Your choice has provided you with a product developed for professional use. Your purchase has also contributed to reducing the burden on the environment and also to the further development of environmentally adapted electronics products.



Why do we have environmentally labelled computers?

In many countries, environmental labelling has become an established method for encouraging the adaptation of goods and services to the environment. The main problem, as far as computers and other electronics equipment are concerned, is that environmentally harmful substances are used both in the products and during the manufacturing. Since it has not been possible for the majority of electronics equipment to be recycled in a satisfactory way, most of these potentially damaging substances sooner or later enter Nature.

There are also other characteristics of a computer, such as energy consumption levels, that are important from the viewpoints of both the work (Internal) and natural (external) environments. Since all methods of conventional electricity generation have a negative effect on the environment (acidic and climate-influencing emissions, radioactive waste, etc.), it is vital to conserve energy. Electronics equipment in offices consume an enormous amount of energy since they are often left running continuously.

What does labelling involve?

This product meets the requirements for the TCO'99 scheme which provides for international and environmental labelling of personal computers. The labelling scheme was developed as a joint effort by the TCO (The Swedish Confederation of Professional Employees), Svenska Naturskyddsforeningen (The Swedish Society for Nature Conservation) and Statens Energimyndighet (The Swedish National Energy Administration).

The requirements cover a wide range of issues: environment, ergonomics, usability, emission of electrical and magnetic fields, energy consumption and electrical and fire safety.

The environmental demands concern restrictions on the presence and use of heavy metals, brominated and chlorinated flame retardants, CFCs (freons) and chlorinated solvents, among other things. The product must be prepared for recycling and the manufacturer is obliged to have an environmental plan which must be adhered to in each country where the company implements its operational policy. The energy requirements include a demand that the computer and/or display, after a certain period of inactivity, shall reduce its power consumption to a lower level in one or more stages. The length of time to reactivate the computer shall be reasonable for the user.

Labelled products must meet strict environmental demands, for example, in respect of the reduction of electric and magnetic fields, physical and visual ergonomics and good usability.

Environmental Requirements

Flame retardants

Flame retardants are present in printed circuit boards, cables, wires, casings and housings. In turn, they delay the spread of fire. Up to thirty percent of the plastic in a computer casing can consist of flame retardant substances. Most flame retardants contain bromine or chloride and these are related to another group of environmental toxins, PCBs, which are suspected to give rise to severe health effects, including reproductive damage in fish-eating birds and mammals, due to the bio-accumulative* processes. Flame retardants have been found in human blood and researchers fear that disturbances in foetus development may occur.

TCO'99 demand requires that plastic components weighing more than 25 grams must not contain flame retardants with organically bound chlorine and bromine. Flame retardants are allowed in the printed circuit boards since no substitutes are available.

Lead**

Lead can be found in picture tubes, display screens, solders and capacitors. Lead damages the nervous system and in higher doses, causes lead poisoning.

TCO'99 requirement permits the inclusion of lead since no replacement has yet been developed.

Cadmium**

Cadmium is present in rechargeable batteries and in the colourgenerating layers of certain computer displays. Cadmium damages the nervous system and is toxic in high doses.

TCO'99 requirement states that batteries, the colourgenerating layers of display screens and the electrical or electronics components must not contain any cadmium.

TCO'99 *-continued*

Mercury**

Mercury is sometimes found in batteries, relays and switches, Mercury damages the nervous system and is toxic in high doses. TCO'99 requirement states that batteries may not contain any Mercury. It also demands that no mercury is present in any of the electrical or electronics components associated with the display unit.

CFCs (freons)

CFCs (freons) are sometimes used for washing printed circuit boards. CFCs break down ozone and thereby damage the ozone layer in the stratosphere, causing increased reception on Earth of ultraviolet light with consequent increased risks of skin cancer (malignant melanoma).

The relevant TCO'99 requirement; Neither CFCs nor HCFCs may be used during the manufacturing and assembly of the product or its packaging.

*Bio-accumulative is defined as substances which accumulate within living organisms.

**Lead, Cadmium and Mercury are heavy metals which are Bio-accumulative.

To obtain complete information on the environmental criteria document, order from:

TCO Development Unit

SE-114 94 Stockholm

SWEDEN

FAX Number: +46 8 782 92 07

E-mail (Internet): development@tco.se

You may also obtain current information on TCO'99 approved and labelled products by visiting their website at:

<http://www.tcodevelopment.com/>

この装置は、情報処理装置等電波障害自主規制協議会（VCCI）の基準に基づくクラスB 情報技術装置です。この装置は、家庭環境で使用することを目的としていますが、この装置がラジオやテレビジョン受信機に近接して使用されると、受信障害を引き起こすことがあります。取扱説明書に従って正しい取扱いをしてください。
本機は付属の電源コードおよび信号ケーブルを使用した状態でVCCI 基準に適合しています。

Declaration of Conformity

Compliance Model Number: C22BW711
Product Family Name: 22" FD Color Monitor

EMC

USA-FCC Class B

This equipment complies with Part 15 of the FCC Rules. Operation is subject to the following two conditions:

1. This equipment may not cause harmful interference.
2. This equipment must accept any interference that may cause undesired operation

European Union

This equipment complies with the following requirements of the EMC Directive 89/336/EEC:

EN55022:1998/CISPR22:1997 Class B

EN55024:1998 Required Limits (as applicable):

EN61000-4-2	4 kV (Direct), 8kV (Air)
EN61000-4-3	3 V/m
EN61000-4-4	1 kV AC Power Lines, 0.5 kV Signal and DC Power Lines
EN61000-4-5	1 kV AC Line-Line and Outdoor Signal Lines, 2 kV AC Line-Gnd, 0.5 kV DC Power Lines
EN61000-4-6	3 V
EN61000-4-8	1 A/m
EN61000-4-11	Pass

EN61000-3-2:1995 + A1, A2, A14 Pass

EN61000-3-3:1995 Pass

Safety

This equipment complies with the following requirements of the Low Voltage Directive 73/23/EEC:

EC Type Examination Certificates:

EN60950:2000, 3rd Edition

IEC 60950:2000, 3rd Edition

Evaluated to all CB Countries

UL 60950, 3rd Edition, CSA C22.2 No. 60950-00

FDA DHHS Accession Number: